

This Space for Architect/Engineer Approval

Job Name _____ Date _____
 Model Specified _____ Quantity _____
 Customer/Wholesaler _____
 Contractor _____
 Architect/Engineer _____

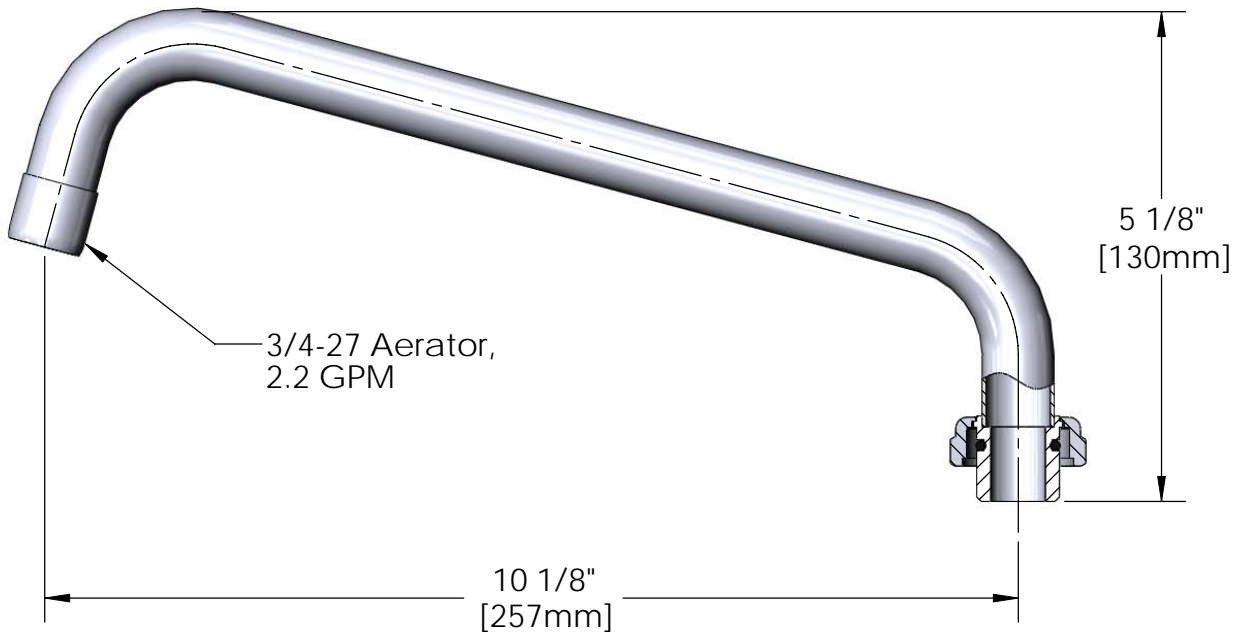
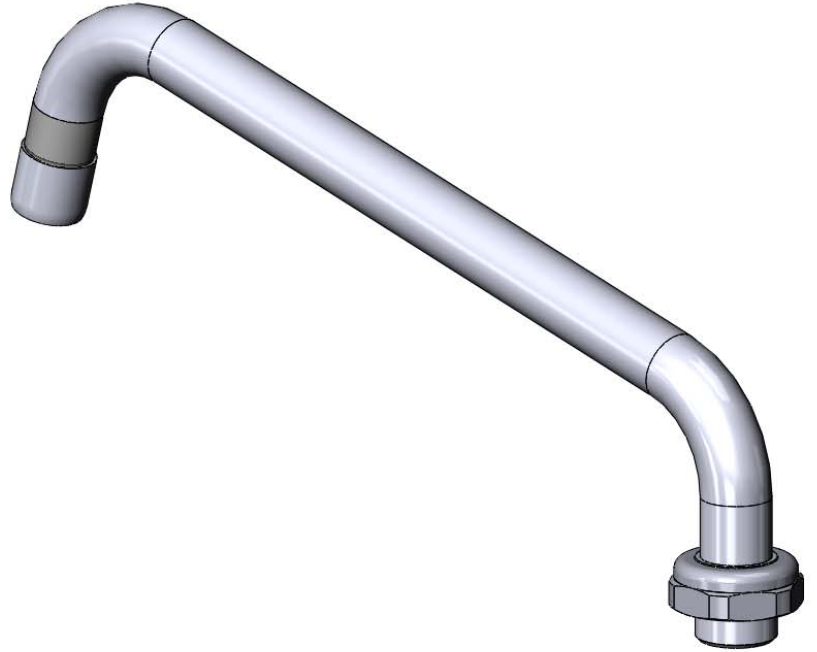

Note:
 Conversion to Rigid Requires
 014200-45 Lock Washer
 (Available Separately)

| | | | | | |
|-------------------------|------------------|--------------|--------------|----------------|-----------------|
| Model Number 5SP-10A | Date 03/12/10 | Scale 1:2 | Drawn DMH | Checked GEF | Approved JHB |
|-------------------------|------------------|--------------|--------------|----------------|-----------------|

Product Specifications:
 10" Swing Nozzle w/ 2.2 GPM Aerator



equip Foodservice Accessories
 2 Saddleback Cove, P.O. Box 1088
 Travelers Rest, South Carolina 29690
 Phone: 800.891.4808 Fax: 800.868.0084